Effect of mooring system on moored ship motions and harbour tranquillity

Shigeki Sakakibara*

Marine Products Engineering Department,
The Yokohama Rubber Co., Ltd.,
2-1, Oiwake, Hiratsuka,
Kanagawa 254-8601, Japan
E-mail: sakakibara.s@mta.yrc.co.jp
*Corresponding author

Masayoshi Kubo

Faculty of Maritime Sciences,
Kobe University, 5-1-1, Fukae-Minami-Machi,
Higashinada-Ku, Kobe 658-0022, Japan
E-mail: kubomasa@maritime.kobe-u.ac.jp

Abstract: Recently, numerical simulation on the motions of ship moored in ports and harbours is carried out to evaluate property of the motions, and is applied to calculating harbour tranquillity directly. However, the simulations take much time, costs and knowledge on evaluation of the results. In this paper, we propose simple graphs for estimating the moored ship motions and mooring loads by a simple index: 'asymmetrical parameter', which is derived from ratio of spring constants between fenders and mooring lines, and demonstrate an evaluation method on harbour tranquillity and effect of the fender type (pneumatic or buckling types) on it.

Keywords: moored ship motions; harbour tranquillity; mooring system; fender; mooring line; subharmonic motions; numerical simulation; wave; wind.

Reference to this paper should be made as follows: Sakakibara, S. and Kubo, M. (2008) 'Effect of mooring system on moored ship motions and harbour tranquillity', *Int. J. Ocean Systems Management*, Vol. 1, No. 1, pp.84-99.

Biographical notes: Shigeki Sakakibara received his Doctor of Engineering in Coastal Engineering from the Osaka University (Japan) in 1995. He is currently a senior engineer at the Marine Products Engineering Department of the Yokohama Rubber Co., Ltd., Japan. His current research interests include developments of marine products and numerical simulation of moored ship motions owing to long-period wave and tsunami.

Masayoshi Kubo is the Dean and a Professor of Faculty of Maritime Sciences of the Kobe University, Japan. He received his Doctor of Engineering in Coastal Engineering from the Osaka University (Japan) in 1981. His current research focuses on sustainable development on sea transportation and maritime sciences.

1 Introduction

Ports and harbours have been constructed as artificial or natural place of shelter for ships to stay safe or to carry out cargo handlings. Since 1960s, the Japanese national policy has aimed at overall economic development, correction of regional difference and improvement of the distribution infrastructure. Large-scale industrial regions have been developed along the coastline, and ocean-facing ports and harbours have been constructed as the core of such industrial regions, in not only Japan but also other countries around the world.

So far, harbour tranquillity is evaluated by wave height in front of a target berth. Namely, if the wave height is less than a rated wave height corresponding to ship size, for example 0.5 m for 10,000 DWT ship, the harbour tranquillity is maintained as 100%. However, it is reported that interruption of cargo handling has occurred under smaller wave heights by large and long-period moored ship motions (e.g., Sakakibara et al., 2001). The moored ship motions are affected by not only the wave height but also the wave period and its direction, and moreover, influenced by mooring system, which is composed of fenders and mooring lines. It is effective and reasonable for the harbour tranquillity index to use the moored ship motions directly, instead of the wave height. To calculate the moored ship motions, numerical simulation method should be used properly.

In this paper, we carry out numerical simulations for several kinds of ships, and investigate influences of ratio of spring constants between fenders and mooring lines, which is named as ‘asymmetrical parameter’, on the moored ship motions and its application to the actual fender design. Furthermore, we propose an evaluation method for operation efficiency of cargo handling by using the moored ship motions directly and investigate effect of the mooring system, especially fender type, on it.

2 Asymmetrical parameter for estimating moored ship motions

2.1 Definition of asymmetrical parameter

In this section, external forces for moored ship motions are considered as beam seas and wind only. Under the external force conditions, sway is a remarkable motion in comparison with the other motions. Thus, we concentrate discussions on sway motion.

To estimate the moored ship motion and mooring forces by using a simple index: ‘asymmetrical parameter’, and to understand their properties well, we define the parameter as follows:

$$\text{Asymmetrical Parameter (A.P.)} = \frac{K_f}{K_{IS}} \quad (1)$$

$$K_f = \sum_{i=1}^{N_f} k_{fi} \quad (2)$$

$$K_{IS} = \sum_{i=1}^{N_l} k_{li} \times \left(\frac{d_i - a_i}{l_i} \right)^2 \quad (3)$$

where K_f is a sum of spring constants of fenders, k_{fi} are spring constants of i th fender at neutral position; $x = 0$, N_f is number of total fenders, K_{ls} is a sum of spring constants of mooring lines in sway direction, k_{li} are spring constants of i th mooring line at neutral position; $x = 0$, N_l is number of total mooring lines, positions; (a_i, b_i, c_i) and (d_i, e_i, f_i) are mooring positions of i th mooring line at dolphin and ship side, and l_i are lengths of i th mooring line as shown in Figure 1.

Figure 1 Asymmetrical parameter for estimation of moored ship motions

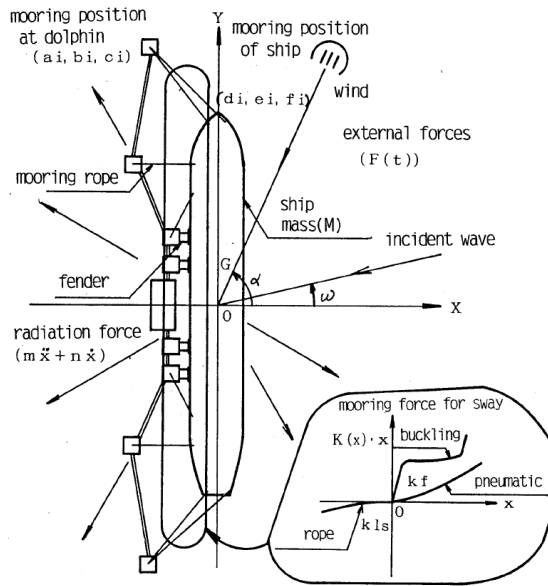

2.2 Calculation conditions for moored ships

The numerical simulations are conducted for oil tankers. The ships are of three sizes as shown in Table 1, and are in ballasted conditions. The mooring arrangements for each ship are set properly, for example, the arrangements for 10,000 DWT ship and 50,000 DWT ship are shown in Figure 2. The mooring systems are determined as shown in Table 2. In the simulations, spring constants of the mooring lines for each ship (K_{ls}) are kept at the actual values; however, those of fenders (K_f) are varied from A.P. = 1 to A.P. = 300. Pretensions of the mooring lines are not considered because this situation is the most dangerous mooring condition when wind acts on the moored ship. The external force conditions are provided as shown in Table 3. The external forces are considered as irregular waves and fluctuating wind, which are generated by Bretschneider–Mitsuyasu and Davenport spectrum, respectively.

Table 1 Ship dimensions

| DWT | Water depth (m) | L (m) | B (m) | D (m) | Draft | Disp.(ton) |
|---------|-----------------|-------|-------|-------|-------|------------|
| 10,000 | 10 | 139 | 19.0 | 9.9 | 4.0 | 6544 |
| 50,000 | 14 | 226 | 32.1 | 16.5 | 6.2 | 30,504 |
| 100,000 | 18 | 270 | 39.0 | 19.2 | 7.2 | 58,969 |

Table 2 Mooring systems

| DWT | Fenders | | Mooring lines | | | |
|---------|--------------|------|---------------|---------|------|-------------|
| | Interval (m) | Pcs. | Dia. (mm) | BL (kN) | Pcs. | Kls. (kN/m) |
| 10,000 | 16.5 | 6 | 60 | 600 | 8 | 178 |
| 50,000 | 2,15,24 | 6 | 60 | 600 | 12 | 206 |
| 100,000 | 3,18,28 | 6 | 65 | 720 | 12 | 199 |

Table 3 External force conditions

| Wave | | Wind | | |
|------------|-----------------|---------------|-------------|---------------|
| $Tl/3$ (s) | $Hl/3$ (m) | Direction (°) | $U10$ (m/s) | Direction (°) |
| 5, 8, 15 | 0.25, 0.5, 0.75 | 0 | 0, 15 | 0, 180 |

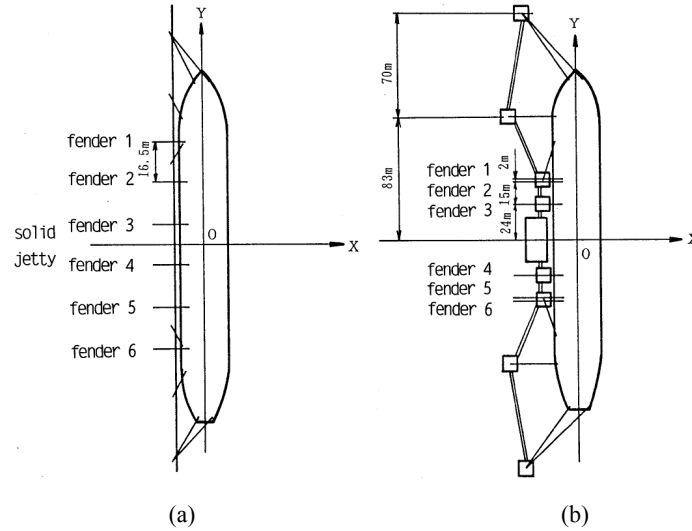
Figure 2 Mooring arrangements for (a) 10,000 DWT and (b) 50,000 DWT ships

In the numerical simulations, a time domain analysis proposed by Cummins (1962) is used as shown in equation (4), where i, j are subscripts of hydrodynamic property in the i -mode as a result of motion in the j -mode, $i, j = 1, 2, \dots, 6$, x_j are motions in j -mode, M_{ij} is mass matrix of vessel, $m_{ij}(\infty)$ is the frequency-independent added mass matrix, L_{ij} is the matrix of retardation functions, D_{ij} is the matrix of viscous damping force coefficients, C_{ij} is the matrix of hydrostatic restoring forces, G_i is the vector of non-linear mooring forces, and F_i are the external forces owing to wave and wind. Hydrodynamic coefficients and exciting forces for the ships are calculated by using 3D domain division method, which uses continuation of velocity potentials and Green's functions (Kubo et al., 1988).

$$\begin{aligned}
 & \sum_{j=1}^6 \{M_{ij} + m_{ij}(\infty)\} \times \ddot{x}_j(t) + \sum_{j=1}^6 \int_{-\infty}^t \dot{x}_j(\tau) \times L_{ij}(t-\tau) d\tau + \sum_{j=1}^6 D_{ij} \times \dot{x}_j(t) \\
 & + \sum_{j=1}^6 C_{ij} \times x_j(t) + G_i = F_i(t) \quad (i=1, 2, \dots, 6)
 \end{aligned} \tag{4}$$

2.3 Simple graph for sway and mooring force

The sway motion expresses displacement in the offshore direction. The fender reaction force indicates for the No. 1 fender in each ship, which is located at ship's bow. The mooring line tension shows the bow spring line for 10,000 DWT ship, and bow breast line for 50,000 DWT and 100,000 DWT ships. The external force condition is considered as only wave without wind in Figure 3. According to Figure 3, tendency of the graphs for sway motion and mooring forces is similar to each other. They rise rapidly after A.P. = 1, and then attain to be in each equilibrium level in proportion to increase in A.P. In smaller size ships or under longer wave periods, the graphs rise rapidly after A.P. = 1, and have larger values.

Figure 3 Simple graphs for estimating sway motion and mooring forces by asymmetrical parameters in different size ships: (a) $T_{1/3} = 5$ s, $H_{1/3} = 0.25$ m and (b) $T_{1/3} = 15$ s, $H_{1/3} = 0.25$ m

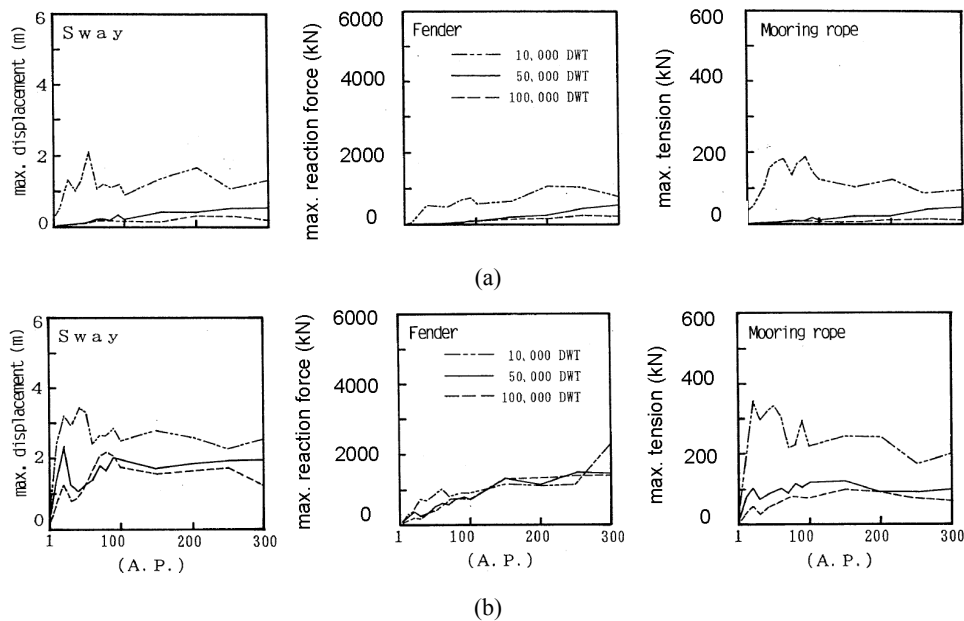

2.4 Validity

To confirm validity of the simple graphs, we carry out some comparisons with calculation results by using actual fenders in the mooring system. The investigation is conducted for 50,000 DWT ship. The actual fenders are selected by berthing energy at the full loaded condition; 666 kNm, which are pneumatic fender and buckling type (solid type) fender, respectively. Each asymmetrical parameter is calculated as A.P. = 29.4 for pneumatic fenders and A.P. = 162.3 for buckling type fenders.

Several simple graphs related to wave periods, heights and wind force for the 50,000 DWT ship are shown in Figure 4. The results for usage of the actual fenders are included in Figure 4.

Figure 4 Simple graphs for estimating sway motion and mooring forces by asymmetrical parameters related to (a) wave period ($H_{1/3} = 0.5$ m); (b) wave height ($T_{1/3} = 8$ s) and (c) wind force ($T_{1/3} = 8$ s, $H_{1/3} = 0.5$ m) (50,000 DWT ship)

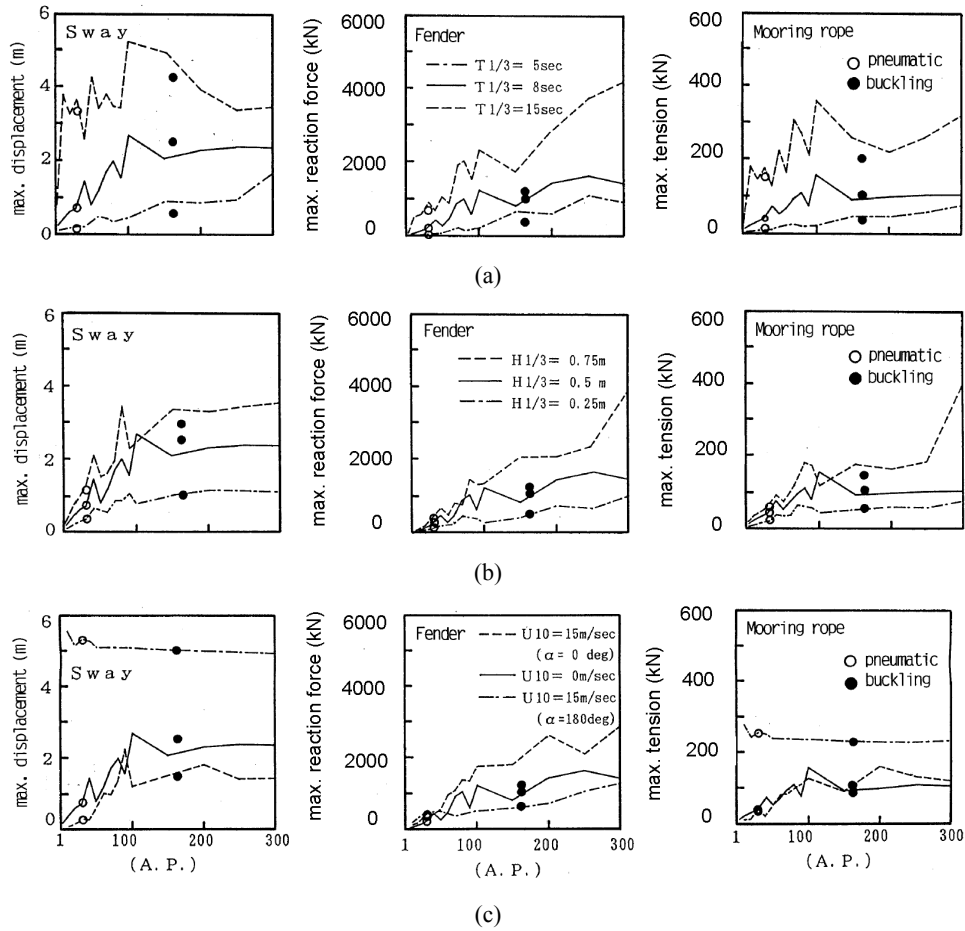

According to Figure 4, the results for usage of the pneumatic fender have good agreements with those of using model fenders in the simple graphs. Furthermore, as shown in Figure 5, the results in time series for sway motion is similar to that for A.P. = 30 in Figure 7(b). These are caused by similarity of their fender performance in load vs. deflection.

In case of usage of the buckling type fender, it is confirmed that the simple graphs for sway motions and mooring line tensions have good agreements with those of using actual fenders in Figure 4. However, the graphs for the fender reaction forces are overestimated when the fenders are compressed at buckling deflection. As shown in Figure 6, the above overestimation in the buckling type fender usage is caused when the fender compression reaches the buckling region in the performance. The overestimated fender reaction forces are modified easily as follows:

- estimation of a deflection in the model fender at the overestimated reaction force (underestimated fender deflection)
- calculation of a deflection in the actual buckling type fender, which corresponds to the same energy absorption from the underestimated deflection (modified fender deflection)
- modification of fender reaction force at the modified deflection in the actual buckling type fender.

Buckling type fenders have hysteresis characteristic, which is not similar to that for the model fenders. According to Figure 4, fairly good agreements for sway motions and mooring line tensions are confirmed in both fenders. The time series for sway motion in Figure 5 are also similar to the results of A.P. = 150 in Figure 7(b). From this, kinetic energy when the moored ship contacts the fender is almost same in both fender usages. The proposed modification method for the fender reaction force in buckling type fender is based on this. It is also confirmed that the above-modified fender deflection is almost equal to the deflection obtained from the numerical simulation results for the actual buckling type fender usage.

Figure 5 Time series for sway ($T_{1/3} = 8$ s, $H_{1/3} = 0.5$ m; 50,000DWT ship): (a) pneumatic and (b) buckling

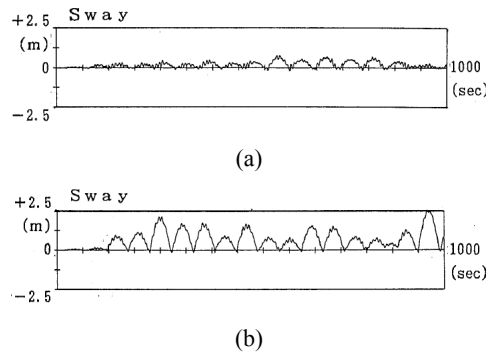

Figure 6 Modification method for fender reaction force in buckling type fender

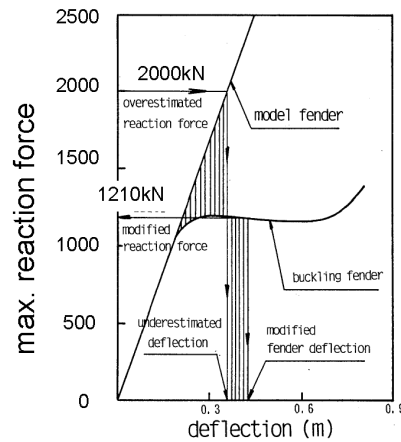
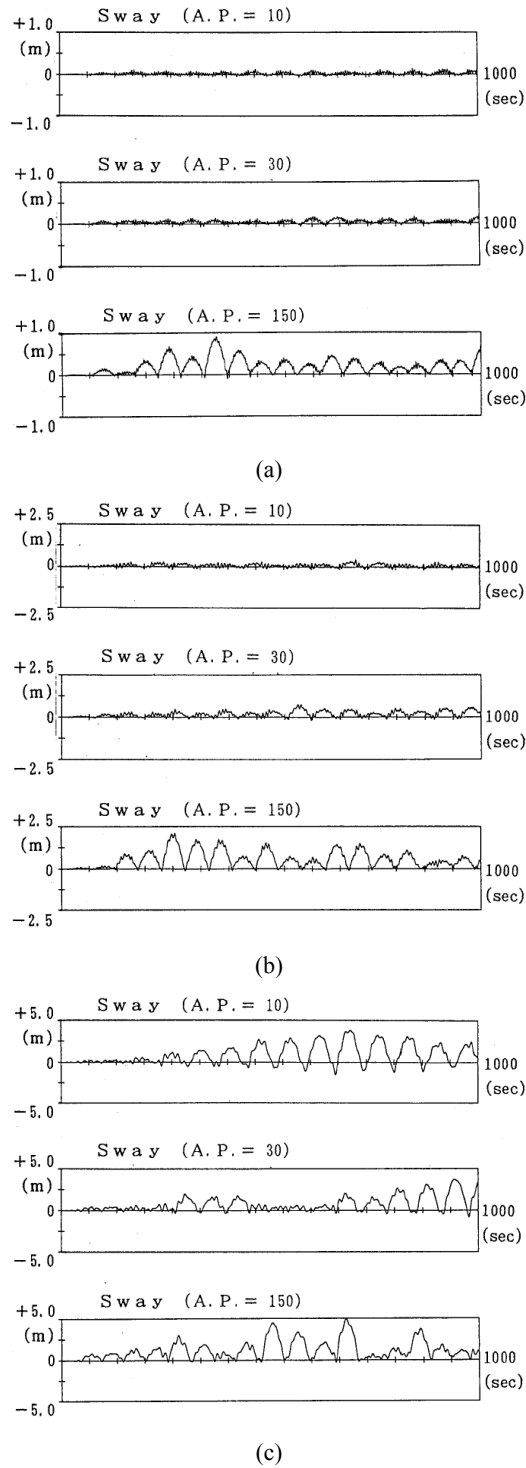

Figure 7 Influences of asymmetrical parameter for subharmonic motions (50,000DWT ship):
 (a) $T_{1/3} = 5$ sec, $H_{1/3} = 0.5$ m; (b) $T_{1/3} = 8$ s, $H_{1/3} = 0.5$ m and (c) $T_{1/3} = 15$ s, $H_{1/3} = 0.5$ m



3 Influence on subharmonic moored ship motions

3.1 Effect of asymmetrical parameter

In this section, we will investigate influences of the asymmetrical parameter on the subharmonic motions. In this consideration, external forces are treated as wave forces in various wave periods ($T_{1/3} = 5, 8, 15$ s), and calculations are conducted for the 50,000 DWT ship.

Time series of sway motions in A.P.=10, 30, 150 are shown in Figure 7. According to Figure 7, duration of the subharmonic motions is not influenced by the wave periods. However, the asymmetrical parameter affects the subharmonic motion considerably, and the subharmonic motions apparently appeared in larger values of the parameter. To estimate the period of subharmonic motions, we try to calculate a natural period of the mooring system, which is composed of only mooring lines. The natural period of the moored ship in sway is calculated as follows:

$$T_{IS} = 2\pi \sqrt{\frac{W_a}{K_{IS}}} \quad (5)$$

where T_{IS} is natural period of moored ship motion in sway, W_a is virtual weight of ship and K_{IS} is a sum of spring constants of mooring lines in sway direction in equation (3). The virtual weight of the moored ship is assumed to be double of the displacement. Thus, the natural period is given as $T_{IS} = 109$ s. This period is almost double of the duration of the subharmonic motion in Figure 7.

We also investigate the subharmonic motions in detail, relating to wave periods. In a wave period at $T_{1/3} = 5, 8$ s in Figure 7(a) and (b), the subharmonic motions are restrained until A.P. = 30. However, the subharmonic motion is considerably generated in A.P. = 150. In a wave period at $T_{1/3} = 15$ s in Figure 7(c), the subharmonic motions already appear in A.P. = 10. In this case, one of the reduction methods against subharmonic motions is to improve the mooring system to be near to A.P. = 1. This method means that it should be necessary to take measures of increasing pretensions for mooring lines, modification of mooring lines from synthetic fibre to wire line, and improvement of fendering system to be softer for the countermeasures.

3.2 Effect of fender type

From the investigation, the subharmonic motion is considered to be a larger moored ship motion when compared with the motions corresponding to wave periods. For cargo handlings, it is better to keep the moored ship quiet at the berth. Allowable ship movements for various cargo handlings are presented in many studies (e.g., PIANC, 1995, 2002). For example, Table 4 shows the movements proposed by Brunn (1981) and Ueda and Shiraishi (1988). According to Table 4 and Figure 7, the apparent subharmonic motions exceed the allowable movements.

It is desirable for improvement on the operation efficiency of cargo handling to prevent from inducing the subharmonic motions. The subharmonic motions are influenced by not only the asymmetrical parameter but also the size of ships and wave period. At any rate, to avoid the subharmonic motions, the ratio of the spring constants between mooring lines and fenders should be near to A.P. = 1. The countermeasure is attained by both improvements on mooring lines and fenders. The improvement for mooring lines is to increase the spring constant, namely to harden the property or to give larger pretension (Kubo et al., 2000). However, handling of the mooring lines and strength of mooring bits for lines restrict them. It is a practical countermeasure to improve the fendering system to be softer. In general, the ratios for usage of buckling type fenders are A.P. = 100–300 and those for usage of pneumatic type fenders are A.P. = 10–30. From this, the improvement of cargo handling is achieved by usage of pneumatic type fenders easily and practically.

Table 4 Allowable ship motions for cargo handlings

| <i>By Brunn</i> | | | | | | |
|--------------------------------|------------------|-----------------|------------------|-----------------|----------------|--|
| <i>Ship type</i> | <i>Surge (m)</i> | <i>Sway (m)</i> | <i>Heave (m)</i> | <i>Roll (°)</i> | <i>Yaw (°)</i> | |
| Tankers | ±2.3 | ±1.0 | ±0.5 | ±4.0 | ±3.0 | |
| Ore carriers | ±1.5 | ±0.5 | ±0.5 | ±4.0 | ±2.0 | |
| Grain carriers | ±0.5 | ±0.5 | ±0.5 | ±1.0 | ±1.0 | |
| Container, Ro/Ro, normal locks | ±0.5 | ±0.3 | ±0.3 | ±3.0 | ±2.0 | |
| Container, Ro/Ro, side | ±0.2 | ±0.2 | ±0.1 | Nil | Nil | |
| Container, Ro/Ro, bow or stern | ±0.1 | Nil | ±0.1 | Nil | Nil | |
| General cargo | ±1.0 | ±0.5 | ±0.5 | ±3.0 | ±2.0 | |
| LNG | ±0.1 | ±0.1 | Nil | Nil | Nil | |

| <i>By Ueda</i> | | | | | | |
|-------------------------|------------------|-----------------|------------------|-----------------|------------------|----------------|
| <i>Ship type</i> | <i>Surge (m)</i> | <i>Sway (m)</i> | <i>Heave (m)</i> | <i>Roll (°)</i> | <i>Pitch (°)</i> | <i>Yaw (°)</i> |
| General cargo ship | ±1.0 | 0.75 | ±0.5 | ±2.5 | ±1.0 | ±1.5 |
| Grain carriers | ±1.0 | 0.5 | ±0.5 | ±1.0 | ±1.0 | ±1.0 |
| Ore carriers | ±1.0 | 1.0 | ±0.5 | ±3.0 | ±1.0 | ±1.0 |
| Oil carriers (domestic) | ±1.5 | 0.75 | ±0.5 | ±4.0 | ±2.0 | ±2.0 |
| Oil carriers (foreign) | ±1.5 | 0.75 | ±0.5 | ±3.0 | ±1.5 | ±1.5 |

4 Influence of mooring system on harbour tranquillity

It is more useful for harbour tranquillity index to use the moored ship motions directly, instead of wave height. In this section, we propose an evaluation method for operation efficiency of cargo handling by using moored ship motions, and investigate effect of fender type on it. The operation efficiency can be regarded as harbour tranquillity.

4.1 Definition of harbour tranquillity based on moored ship motions

The operation efficiency of cargo handling proposed in this paper is calculated by numerical simulation of moored ship motions in equation (4), directly. As shown in Figure 8, the operation efficiency shall be defined by time series results of the ship motions as follows:

$$\text{Operation Efficiency (\%)} = (1 - a/b) \times 100 \tag{6}$$

where 'a' is excess data against rated allowable ship movement and 'b' is whole data of the time series. The rated allowable ship motions are shown in Table 4.

Figure 8 Definition of operation efficiency of cargo handling based on moored ship motions

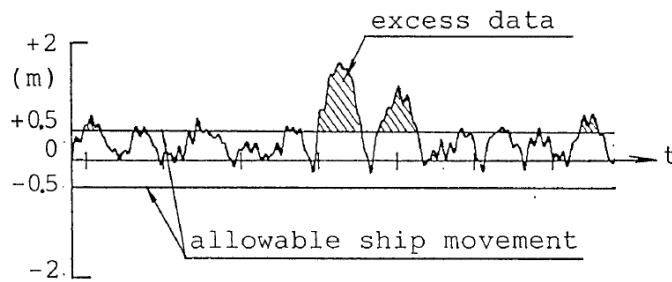

4.2 Calculation of annual harbour tranquillity

4.2.1 Model harbour layout, wave and wind characteristics

Annual operation efficiency of cargo handling for a model harbour, which is shown in Figure 9, is demonstrated. The wave characteristics of the harbour are represented as statistical characteristics, classifications and cumulative distribution of wave period and significant wave height as shown in Figure 10. Wind characteristics refer to classification of wind speed and direction of the harbour.

Figure 9 Layout of model harbour

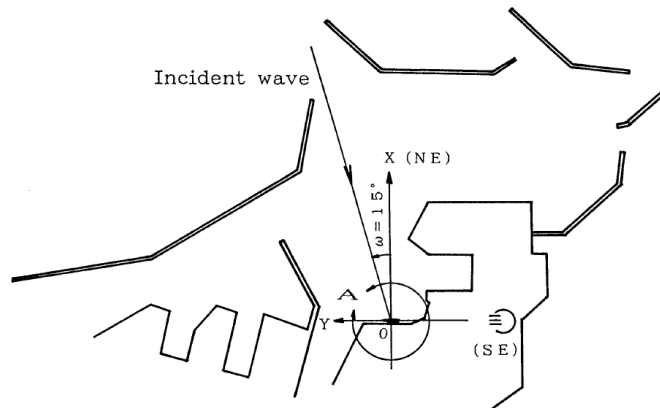
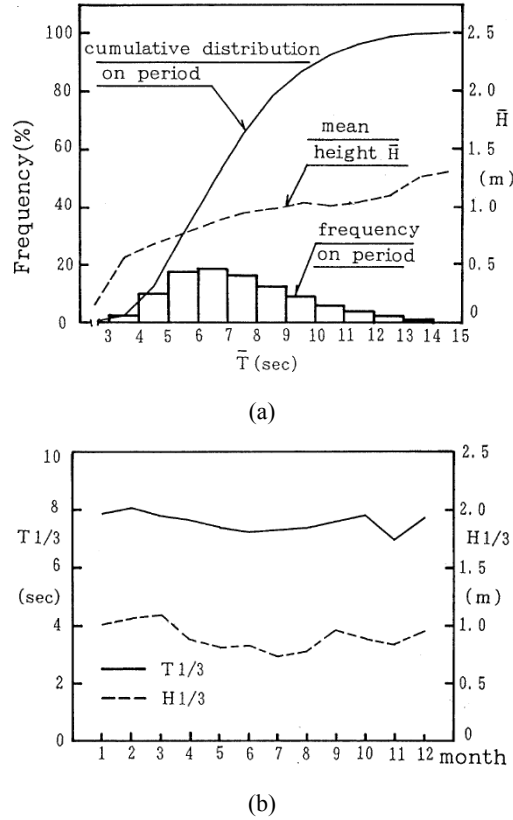

Figure 10 Wave characteristics of the model harbour: (a) classification and cumulative wave and (b) monthly significant wave



4.2.2 Calculation conditions

The calculations are carried out for a 50,000 DWT bulk carrier ($L = 200$ m, $B = 32.2$ m, $D = 18.2$ m, $d = 7$ m at ballast condition, $W = 34,000$ tons) moored along solid jetty. The solid jetty is located at ‘A’ in the harbour as shown in Figure 9. The water depth is 14 m.

The ship is moored by 60 mm diameter nylon ropes and fenders as shown in Figure 11. The number of lines is 12. The fenders are selected for a berthing energy at the full loaded condition; $E = 283$ kNm, which are buckling type (solid type) 1000 H fenders, and the interval of each fender is 18 m.

The external forces for the moored ship are considered to be irregular waves and fluctuating wind. In principle, the wave condition must be estimated by calculation of wave spectrum at the berth. We simplify the wave condition at the berth as follows.

Wave period ($T_{1/3}$); Offshore wave period

$$\text{Height } (H_{1/3}); H_{1/3} = 0.5 \text{ m for } T_{1/3} < 10 \text{ s}$$

$$; H_{1/3} = 0.2 \text{ m for } T_{1/3} > 10 \text{ s}$$

$$\text{Direction } (\omega); \omega = 15^\circ$$

(This is angle from the harbour entrance to berth ‘A’.)

The wind condition is established as the predominant wind direction; SE (astern wind for 50,000 DWT bulk carrier), and the wind speed $U_{10} = 10$ m/s or 0 m/s.

Figure 11 Mooring conditions of 50,000 DWT bulk carrier

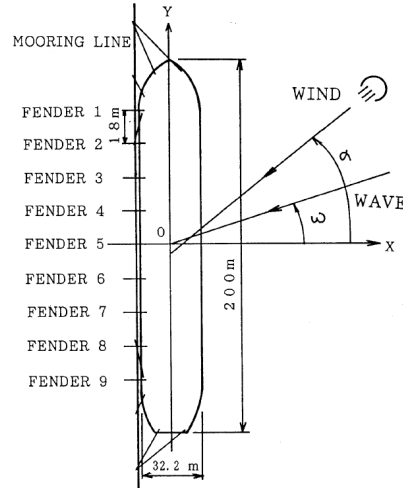

4.2.3 Calculation results on harbour tranquillity

The calculation results of the operation efficiency for wave periods and each month are shown in Figure 12. Cumulative distributions of the operation efficiency with or without wind are also included in Figure 12(a). It shall be defined as follows:

$$\text{Cumulative Distribution of Operation Efficiency (\%)} = 100 - \sum_{i=1}^i (a_i / b_i) \times p_i \quad (7)$$

where a_i is excess data against allowable ship movement at wave period T_i , b_i is whole data of the time series at wave period T_i , p_i is frequency at wave period T_i , and T_i is significant wave period; $T_i = 1$ s, 2 s, 3 s, ... ($i = 1, 2, 3, \dots$).

As shown in Figure 12(a), it is confirmed that the operation efficiency decreases at longer wave periods in spite of smaller wave height. From this property of the classification, the cumulative distribution is maintained at almost 100% under shorter wave periods; however, it begins to decrease at longer wave periods, which is about 10 s or longer. The monthly operation efficiency, as shown in Figure 12(b), varies corresponding to the monthly wave periods. The operation efficiency for 50,000 DWT bulk carriers is given as 100% on the basis of the wave height consideration. From these mentions, some differences appear between each value, which are given by this proposed method and the ordinary evaluation method owing to wave height. It is well known that the moored ship motions and the operation efficiency are influenced by not only the wave heights but also the wave periods and their directions (e.g., Ueda and Shiraishi, 1988). Thus, it is considered that this proposed evaluation method for operation efficiency of cargo handling represents the actual harbour tranquillity.

Figure 12 Operation efficiency (Buckling type fender usage): (a) classification and cumulative efficiency and (b) monthly efficiency

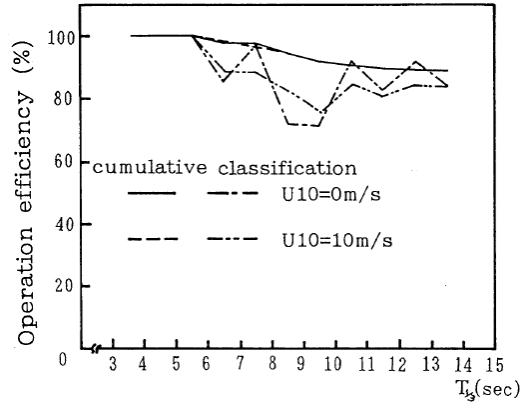

(a)

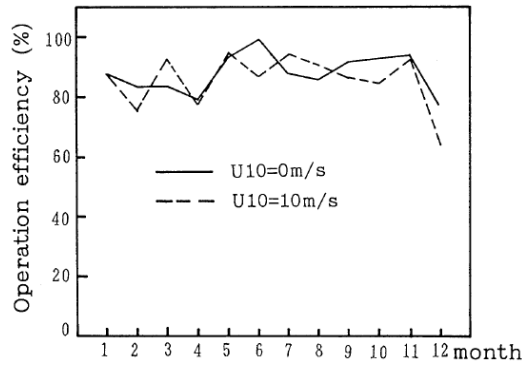

(b)

4.3 Improvement of harbour tranquillity

We try to investigate influences of mooring system for operation efficiency of cargo handling by using this proposed evaluation method. Figure 13 shows calculation results in which the bucking type fenders are replaced with pneumatic type fenders of equivalent energy absorption capacity. The fender performances for both fenders are shown in Figure 14.

In comparison with Figures 12(a) and 13(a), the cumulative distributions for usage of pneumatic type fenders are maintained at 100% up to longer wave periods. The monthly operation efficiency, as shown in Figure 13(b), is also maintained at almost 100% through a year. From these comparisons, the operation efficiency is considerably influenced by characteristics of the fender type and the mooring system. To achieve effective harbour tranquillity, it should be necessary to modify the mooring system from asymmetrical system to symmetrical or weak asymmetrical one.

Figure 13 Operation efficiency (Pneumatic type fender usage): (a) classification and cumulative efficiency and (b) monthly efficiency

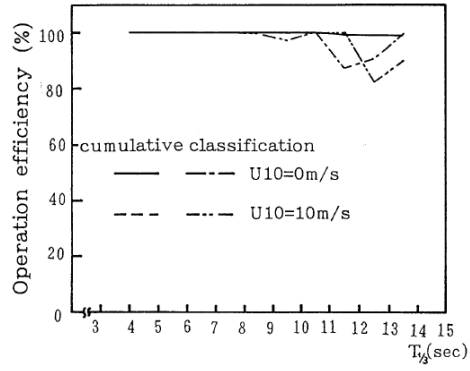

(a)

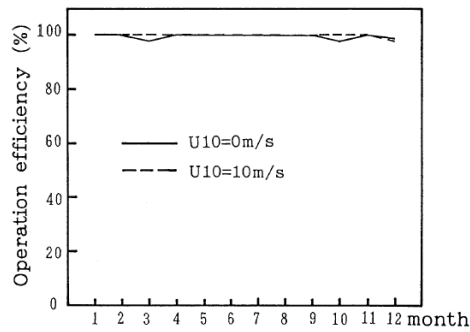

(b)

Figure 14 Fender property of the both fenders

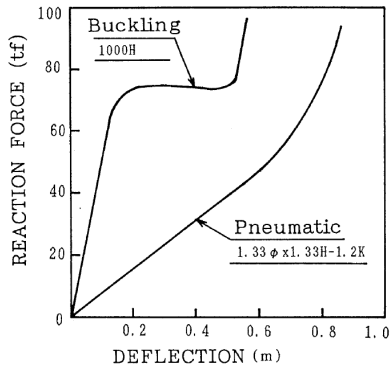

5 Conclusions and remarks

In this paper, we have investigated effect of mooring system, especially fender type, on moored ship motions and harbour tranquillity by using numerical simulation of moored ship motions. The obtained results are summarised as given here.

- ‘Asymmetrical parameter’, which is a ratio of spring constants between fenders and mooring lines, has been defined. The parameter influences the subharmonic motions considerably.
- Several simple graphs by asymmetrical parameter for estimating ship motion and mooring forces have been demonstrated and verified.
- Evaluation method for operation efficiency of cargo handling by using moored ship motions directly has been proposed. Some differences have appeared between each value, which are given by this proposed method and the ordinary evaluation method based on only wave height.
- It is confirmed that this proposed evaluation method using moored ship motions directly represents the actual harbour tranquillity, compared with the ordinary only wave height consideration method.
- The operation efficiency, which is equivalent to harbour tranquillity, has been considerably influenced by characteristics of the fender type and the mooring system. To achieve effective harbour tranquillity, it should be necessary to modify the mooring system from asymmetrical system to symmetrical or weak asymmetrical one.
- To achieve the symmetrical or weak asymmetrical system, which contributes to effective harbour tranquillity, usage of pneumatic type fenders is useful.

Acknowledgements

We are grateful for large amounts of computing results of the moored ship motions provided by graduate students at the Kobe University. We also thank ports and harbour bureau in Japan for preparing data on waves and wind at each port and harbour precisely.

References

- Brunn, P. (1981) ‘Breakwater versus mooring system’, *The Dock and Harbor Authority*, Vol. XLII, No. 730, pp.126–129.
- Cummins, W.E. (1962) *The Impulse Response Function and Ship Motions*, D.T.M.B, Report 1661, Washington DC.
- Kubo, M., Saito, K., Sakakibara, S., Kitano, M. and Sawada, M. (2000) ‘A study on suitable mooring system for large and small ships under waves and wind’, *Proc. Int. Coastal Eng., ICCE*, Australia, pp.3629–3642.
- Kubo, M., Shimoda, N. and Okamoto, S. (1988) ‘The time domain analysis on moored ship motions’, *Proc. Int. Coastal Eng., ICCE*, Spain, pp.2952–2965.
- PIANC (1995, 2002) *Criteria for Movements of Moored Ships in Harbors*, Report of WG No. 24.
- Sakakibara, S., Sato, K., Kubo, M. and Yazaki, F. (2001) ‘A study on long-period moored ship motions in a harbor induced by a resonant large roll motion under long-period waves’, *Proc. Int. Offshore and Polar Eng., ISOPE*, Vol. 3, pp.326–333.
- Ueda, S. and Shiraishi, S. (1988) ‘The allowable ship motions for cargo handling at wharves’, *Report of Port and Harbor Res. Inst.*, Vol. 27, No. 4, pp.3–61.